

Communication Interface Module Replacement

Removal Procedure

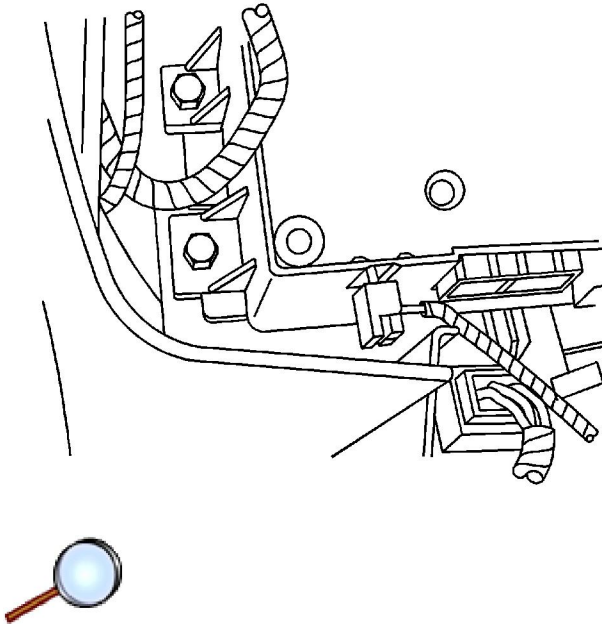

Important: The vehicle communication interface module (VCIM) has a specific set of unique numbers that tie the module to each vehicle. These numbers, the 10-digit station identification and the 11-digit electronic serial number, are used by the National Cellular Network and OnStar® to identify the specific vehicle. Because these numbers are tied to the vehicle identification number of the vehicle, you must never exchange these parts with those of another vehicle.

1. Remove the communication interface module screws.

The communication interface module is located forward of the floor console and under the instrument panel. There are two screws on the passenger side and one toward the driver side.

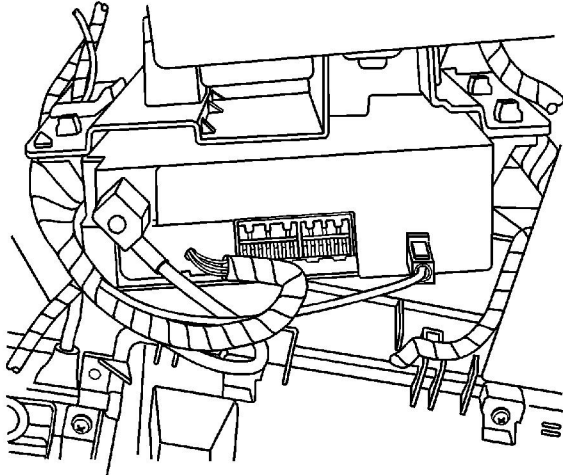

2. Disconnect the mobile telephone antenna cable from the communication interface module by pulling outward on the square plastic housing.
3. Disconnect the electrical connectors.
4. Disconnect the navigation antenna coaxial antenna cable from the module.
5. Remove the communication interface module.

Installation Procedure

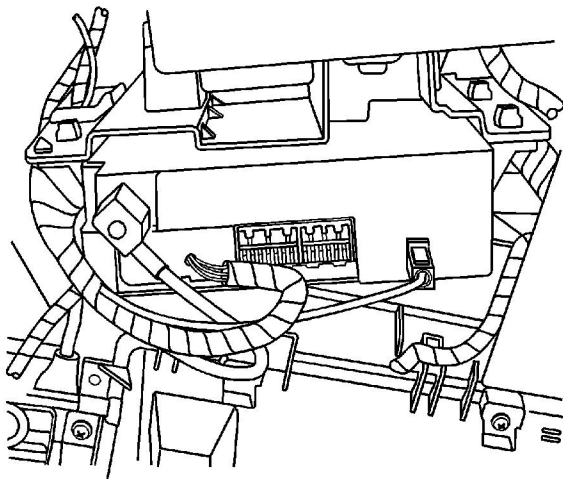

1. If you are replacing the VCIM, record the 10-digit standard identification (STID) number and the 11-digit electronic serial number (ESN) from the labels on the new module.

Notice: Before you install the antenna cable connector of the global positioning system

(GPS) to the vehicle communication interface module (VCM), align the connector properly in order to avoid damaging the connector.

2. Connect the navigation antenna coaxial cable to the module.
3. Connect the electrical connectors.
4. Connect the mobile telephone antenna cable to the module by pushing inward on the square plastic housing.

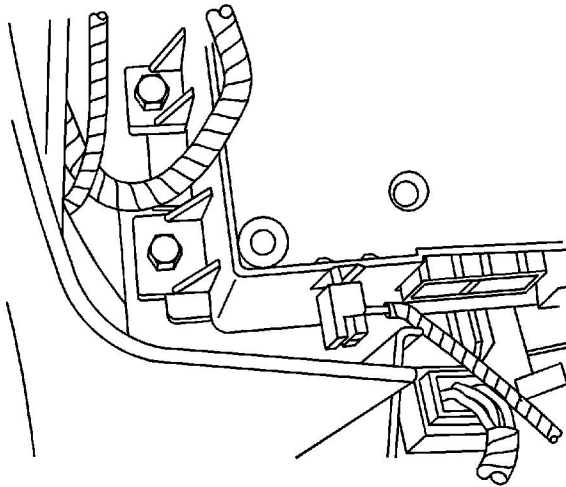

5. Align the module to the vehicle antenna module bracket.

Notice: Refer to [Fastener Notice](#) in the Preface section.

6. Install the communication interface module screws.

Tighten

Tighten the screws to 2 N·m (18 lb in).

Important: After replacing the vehicle communication interface module, you must reconfigure the OnStar® system. Failure to reconfigure the system will result in an additional customer visit for repair. In addition, pressing and holding the white dot button on the keypad will NOT reset this version of the OnStar® system. This action will cause a DTC to set.

7. Reconfigure the OnStar® System. Refer to [OnStar Reconfiguration](#) .